

Drahtschweißmodul

KSM-360-810

Wire welding module
KSM-360-810

Technische Details zu KSM-360-810

Technical Details for KSM-360-810

Hauptabmessung Dimensions	L300 x H780 x T670 [mm]
Gewicht Weight	~300kg - 350kg
Ausrichtung Orientation	Y=+/-40 Z=+/-5
Gerätetypen Device Types	VDG-810-E

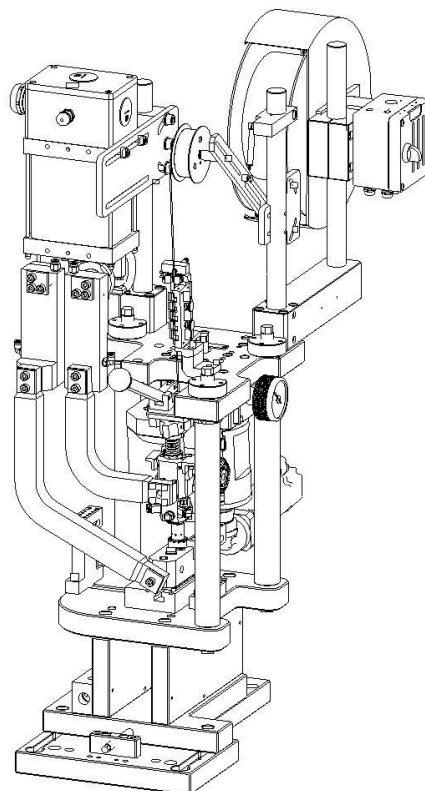

Technische Zeichnungen

Technical Drawings

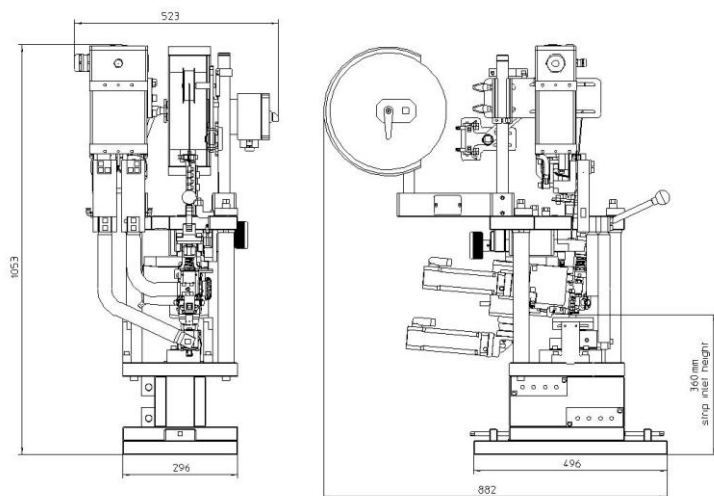

Montageoptionen

Mounting options

Mounting options for upper mounting :

- Welding head VDG-810-E

Mounting options for lower mounting:

- Lower pin electrode unit (UEEH-SE)

Extensions:

- Transformer mounting (TRA)
- Profile- and wire decoiler (PDH)
- Wire straightener (DRW)
- Pilot module